

Waterfall

bath enclosures

Model 03 Door & Panel Frame For 39, 39C, 79 & 79C Installation Instructions

Installation Tools Required: Tape Measure, Masking Tape, Level, #2 Phillips Screwdriver, Drill with 1/8" and 3/16" bits, mallet or hammer, wood block, razor or sharp knife, hacksaw, pencil, clear silicone caulking.

Optional: Miter Box, File and Center-Punch.

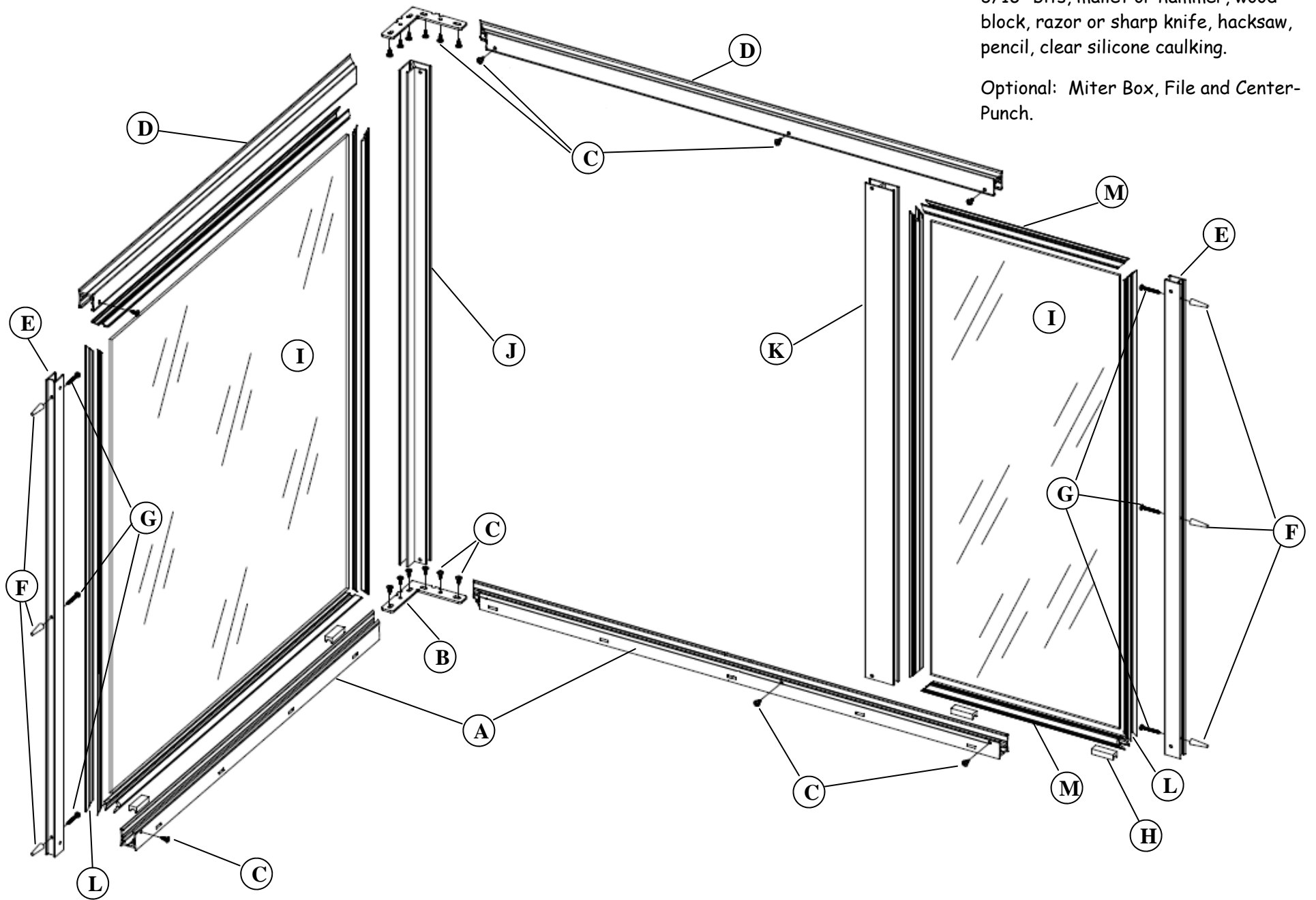

1 The Waterfall Model 03 Frame and associated doors are reversible and may be installed pivot or hinge left as well as pivot or hinge right. Doors may hinge from the wall or the center post. See illustration.

The pivot or hinge jamb should always be opposite the shower head as shown in the illustration.

Caution: Doors must always open outward.

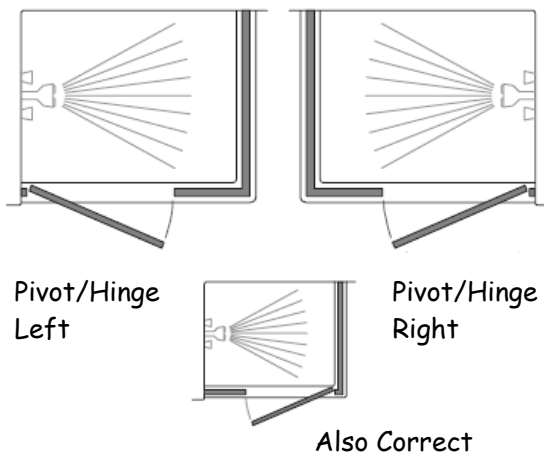

3 Measure the opening at the bottom of the shower and trim the curbs [A] to fit the shower sill. The curb should sit near the centerline of the sill. If necessary use a file to round the ends of the curb to fit the sill.

Drill 3/16" holes in the interior face of the curbs as shown. Position the curb on the sill and mark its position with pencil on the interior and exterior.

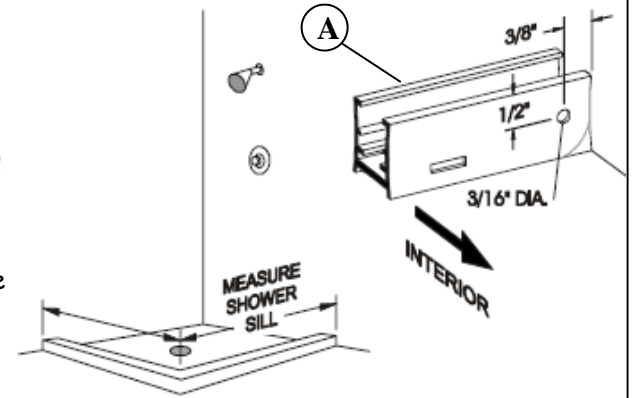

2 Identify the curbs with weep slots [A]. Assemble the sections by sliding a 90° anchor plate [B] into the ends and pressing the sections together. The weep slots should be to the inside of the unit. Drill matching 1/8" holes in the curbs using the holes in an anchor plate as a guide. Attach the anchor plate to the curb using four #8 x 1/4" truss head screws [C]. Be sure the miter is pressed tightly together as you tighten the screws. Extra screws may be installed to increase rigidity of the miter joint.

Assemble the header sections [D] in the same manner and set the assembly aside.

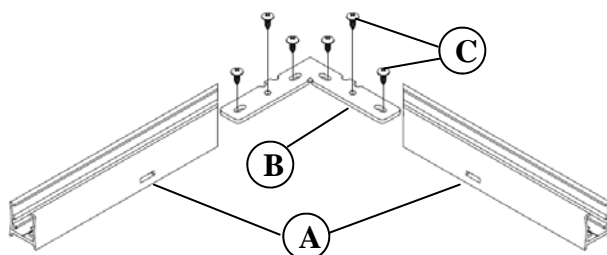

4 Place 2 wall jambs [E] into the ends of the curb [A]. Use masking tape to hold the curb in position. Plumb both jambs and mark the hole locations on the wall. Remove the jambs and drill the walls for mounting.

Drill six 3/16" diameter holes for tile or marble walls and insert the plastic wall anchors [F]. Attachments to fiberglass or acrylic units can be made in two ways. If reinforcement is built into the wall, drill three 1/8" diameter holes to install the mounting screws directly into the reinforcement. If there is no reinforcement, drill 3/16" holes and install plastic wall anchors or Molly bolts (not supplied).

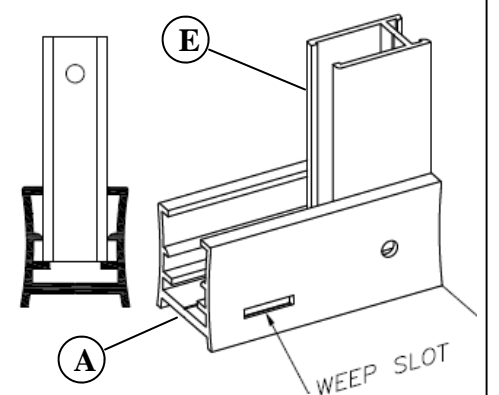

5 Clean the shower walls, sill, curb and wall jambs to remove any debris. Apply a 1/4" bead of caulk along the inside of the pencil lines from step #3. Replace the curb assembly in the exact position marked. Caulk the inside of the curb where the ends meet the wall.

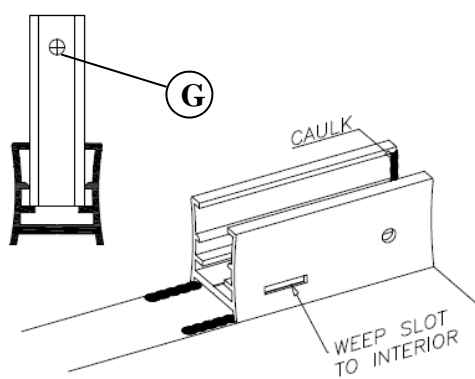

Replace both wall jambs and attach to the wall with six #8 x 1 1/2" truss head screws [G].

6 Place setting blocks [H] in the curb [A] as shown to support the fixed glass panels [I]. The setting blocks should be positioned approximately 3" from each corner of the glass. Set the first glass panel into place on the setting blocks and approximately 1/2" into the wall jamb [E].

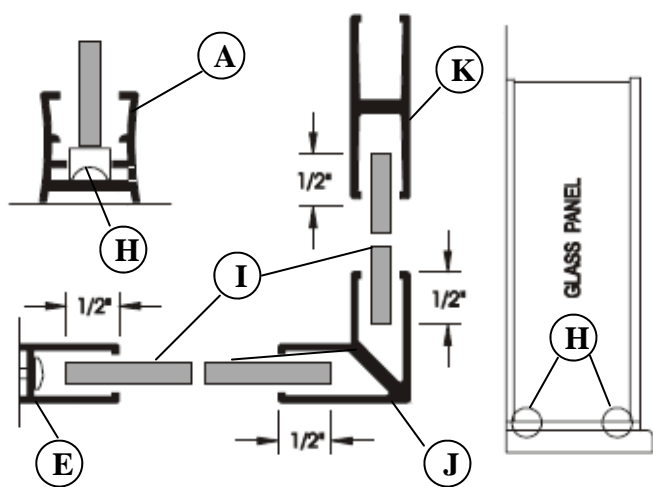

Place a strip of masking tape 1/2" from the edge of the glass to mark the position.

NOTE: Obscure glass should be installed with the rough surface to the exterior of the unit.

Press the 90° post [J] into the curb and position it to overlap the glass 1/2". Use masking tape to hold the post in position. Set the second glass panel into place then press the 180° post [K] into the curb and secure with tape. Glass bite may be varied from 1/4" to 3/4" for out-of-plumb walls.

7 Hold the 90° post plumb and measure horizontally from the top of each wall jamb to the outside edge of the post. Add 3/16" to each measurement to determine the measurement on the header assembly from the outside mitered edge to the squared ends. Trim the header assembly to fit.

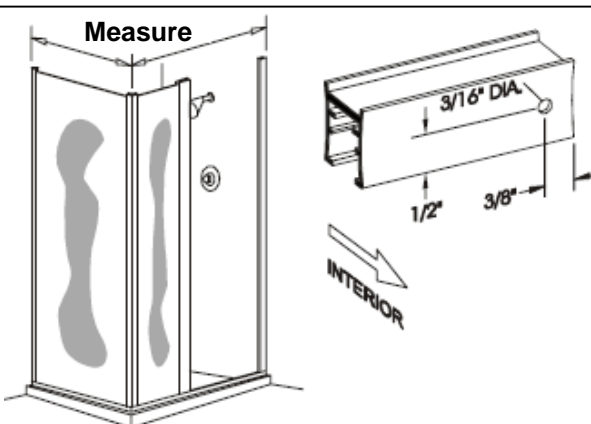

Drill a 3/16" hole on each end of the interior face of the header assembly as shown.

8 Press the header assembly over the wall jambs, 90° post and 180° post. Check all posts for plumb. Adjust by varying the overlap of the header over the wall jambs. It may be necessary to trim the ends of the headers where they meet the wall. The minimum horizontal dimension of the door opening is the door panel width plus 3/4", maximum is door panel width plus 1 3/4".

Using the holes in the ends of the header and curb as a guide drill four 1/8" holes into the wall jambs. Drill four 1/8" holes through the header and curb into the two posts as shown in the illustration. Enlarge the four outer holes with a 3/16" drill for clearance of the self-tapping screws. Secure the header and curb assemblies to the wall jambs and posts with eight #8 x 1/4" truss head screws.

CAUTION: Slide the glass panels away from the jambs or posts before drilling to prevent breakage.

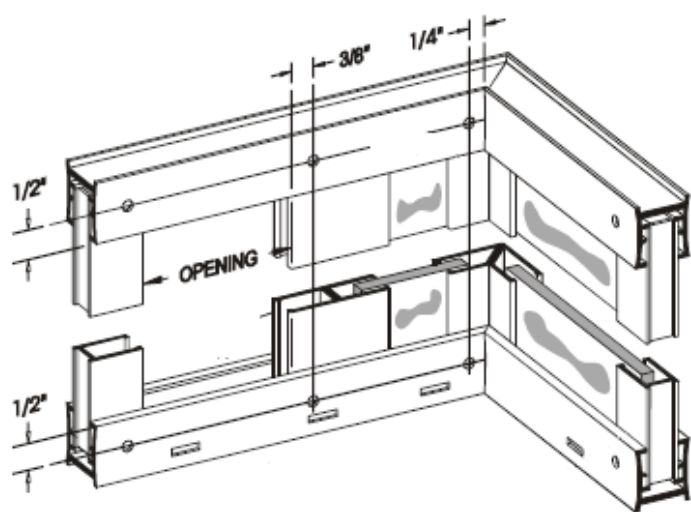

9 Two vinyl profiles are used for glazing the fixed glass panels. The smaller profile [L] is used in the jambs and the larger profile [M] is used in the header and curb. These vinyls are designed to fit tightly between the glass and framing for leak resistance and to add structural strength. Use glass cleaner for lubrication and a wood block to press the vinyl into place.

FIXED GLASS PANEL	VERTICAL	HORIZONTAL
1/4" GLASS REQUIRES:	V-219 L	V-220 M
3/16" GLASS REQUIRES:	V-226 NOTCH	V-225 NOTCH

9 Cut 4 pieces of the smaller vinyl [L] 1" longer than the vertical opening and trim the ends to a 45° angle. The extra 1" helps prevent gapping from shrinkage. Center the glass panel [I] in the frame. Cut four 1" or 2" pieces of the small vinyl and press into the jambs on both sides to temporarily hold the glass. Starting on the outside exterior jamb press each end of a long piece of vinyl into the frame and work toward the middle being careful not to stretch the vinyl.

Repeat this procedure for the remaining three pieces.

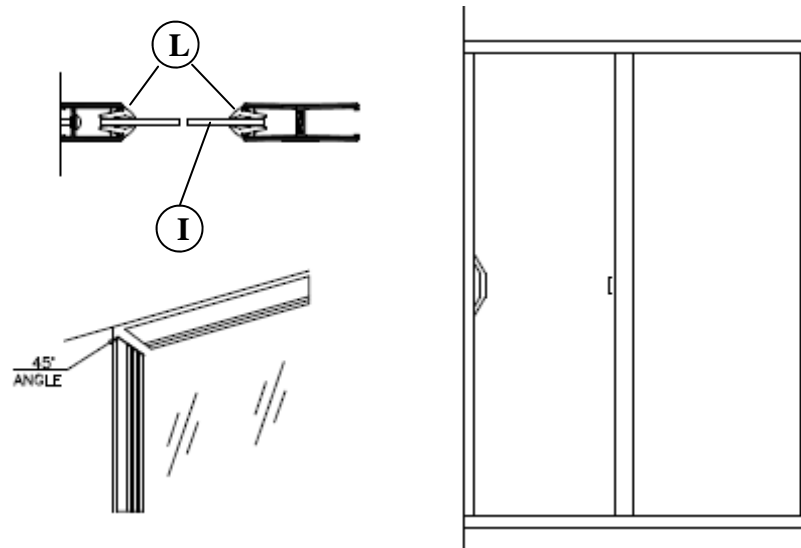

10 Cut 4 pieces of the larger vinyl [M] 1/2" longer than the horizontal opening and trim the ends to a 45° angle. Install the top exterior vinyl starting at both ends and working toward the middle being careful not to stretch the vinyl.

Repeat this procedure for the remaining three pieces.

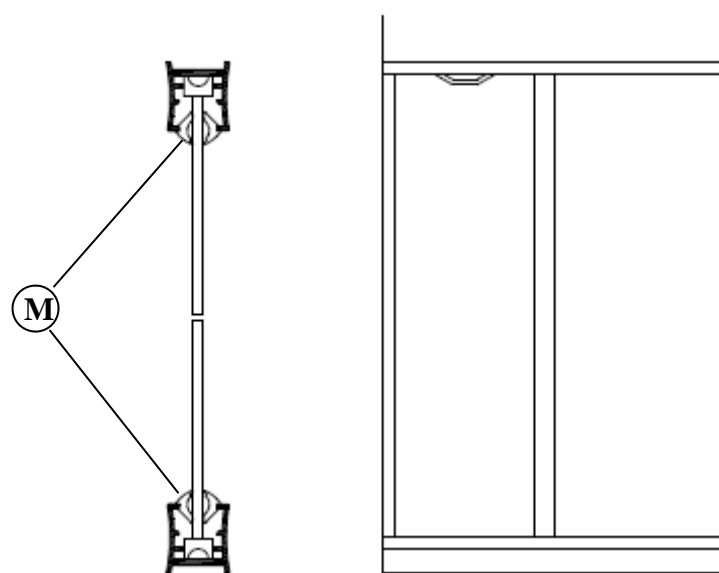

Caulk the interior of the unit where the jambs meet the walls and where the curb meets the sill. Allow the caulk to cure 24 hours before using the shower.

Clean your new Waterfall Enclosures with a soft cloth and a non-abrasive cleaner with a neutral Ph. Do not use acid based cleaners, vinegar or scouring pads to clean your unit.